

Laguna and the LSC

*Luis Labarga, University Autónoma Madrid
LSC Scientific Committee 6th Meeting
20100415*

1. What is LAGUNA ?
2. Feasibility study for LAGUNA at the LSC

What is **LAGUNA** ?

- The current European approach to the next generation, liquid [Mt-like], p-decay and neutrino detectors

- It considers seven candidate sites:

CUPP @ Pyhäsalmi **mine**, Finland

IUS @ Boulby **mine**, UK

SUNLAB @ Sieroszowice **mine**, Poland

IFIN-HH @ Unirea **mine**, Romania

LSM @ Frejus **tunnel**, France

New-Italian-Site @ CNGS beam halo, Italy

LSC @ Canfranc RW **tunnel**, Spain

- It considers three different detector technologies:

- Water-Cherenkov: ~ 1 Mt
- Liquid-Argon TPC: ~ 0.1 Mt
- Liquid-Scintillator: ~ 0.05 Mt



LNGS is not there (i!)

What is LAGUNA ? (II)

- a pre-Collaboration is formed. It did apply for 5 M€ funding to the EU within the program FP7-INFRASTRUCTURES-2007
- Only 1.7 M€ were granted. The explicit request by the EU was to focus in the Feasibility Study (FS), mainly Geotechnic, of the 7 candidate sites.

Italy (INFN) is not there (i!)

LAGUNA Governance structure		v2.0 / 14/10/08
Coordinator		A. Rubbia
Deputy-Coordinator		??
Governing Board		
<i>Coordinator</i>		A. Rubbia
<i>Deputy-coordinator</i>		??
<i>Administrator</i>		F. Petrolo
<i>WG2 coordinator</i>		F. von Feilitzsch
<i>WG3 coordinator</i>		N. Spooner
<i>WG4 coordinator</i>		A. Zalewska
<i>Academic partners' representatives</i>		
ETH Zurich		A. Marchionni
U-Bern		A. Ereditato
U-Jyväskylä		J. Maalampi
UOULU		T. Enqvist
CEA		M. Zito
IN2P3		Th. Patzak
MPG		M. Lindner
TUM		L. Oberauer
IFJ PAN		Jan Kisiel - US (for IFJ PAN)
LSC		A. Bettini ←
UAM		L. Labarga ←
UDUR		S. Pascoli
USFD		P. Lightfoot
AU		H. Fynbo
IFIN-HH		R. Margineanu
<i>Industrial partners' representatives (ex-officio)</i>		
Rockplan		G. Nuijten
KGHM CUPRUM		W. Pytel
IGSMiE PAN		K. Slizowski
Technodyne		J. Thompson
AGT		M. Temussi
Lombardi		P.F. Bertola

The **LAGUNA** detector-technology approaches

Water-Cherenkov \Rightarrow MEMPHYS

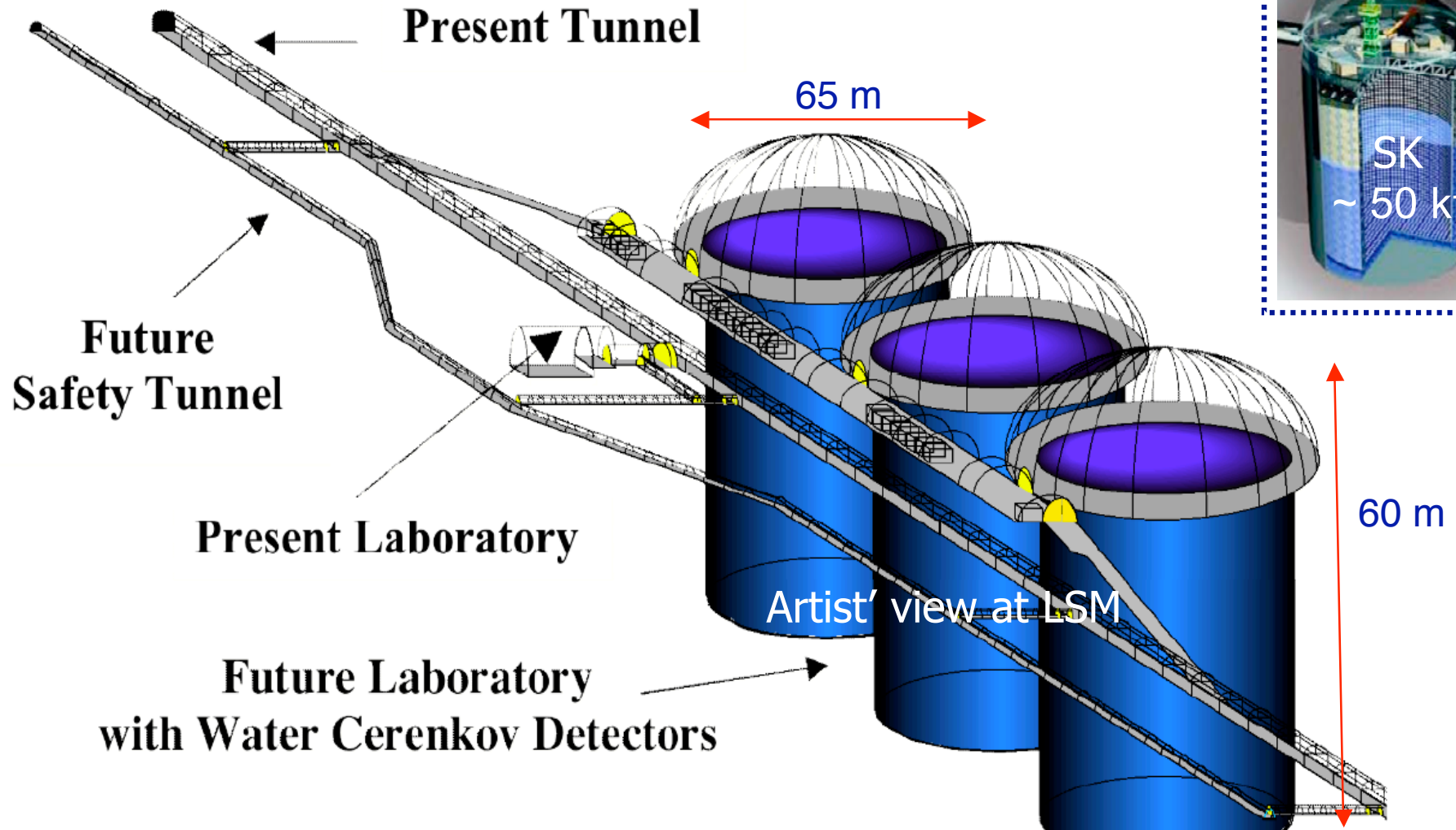
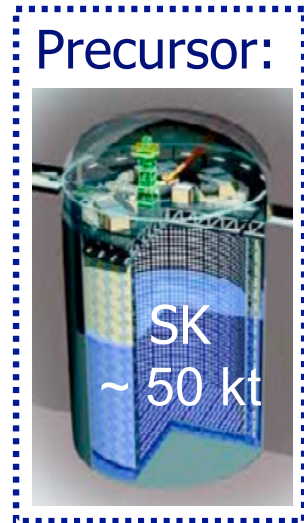

- hopefully with **Gd** solute
- each tank ~250 kt
- tank size limited by light attenuation length ($\lambda \sim 80\text{m}$) and pressure on PMTs
- readout : $\sim 3 \times 81\text{K}$ 12" PMTs, 30% geom. cover

LAGUNA (MEMPHIS) is the European “competitor” of SuperKamiokande’s successor: HyperKamiokande

- they have the expertise
- they have a powerful ν beam
- they have a wonderful “push”

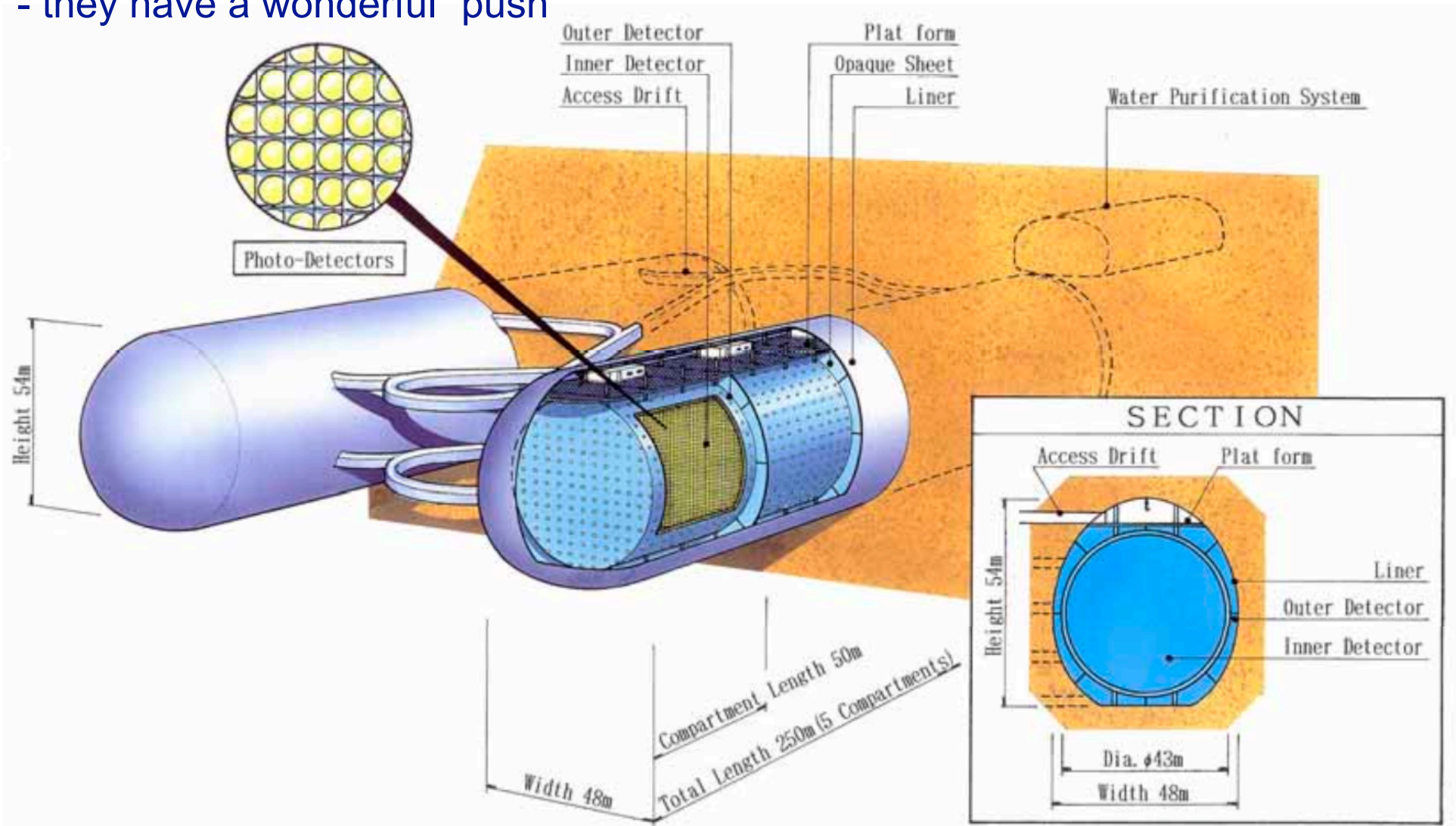

Liquid Scintillator ⇒ LENA

DETECTOR LAYOUT

~ 50 kt Liquid Scintillator

Cavern

height: 115 m, diameter: 50 m
shielding from cosmic rays: ~4,000 m.w

Muon Veto

plastic scintillator panels (on top)
Water Cherenkov Detector
1,500 phototubes
100 kt of water
reduction of fast
neutron background

Steel Cylinder

height: 100 m, diameter: 30 m
70 kt of organic liquid
13,500 phototubes

Buffer

thickness: 2 m
non-scintillating organic liquid
shielding external radioactivity

Nylon Vessel

parting buffer liquid
from liquid scintillator

Target Volume

height: 100 m, diameter: 26 m
50 kt of liquid scintillator

vertical design is favourable in terms of rock pressure and buoyancy forces

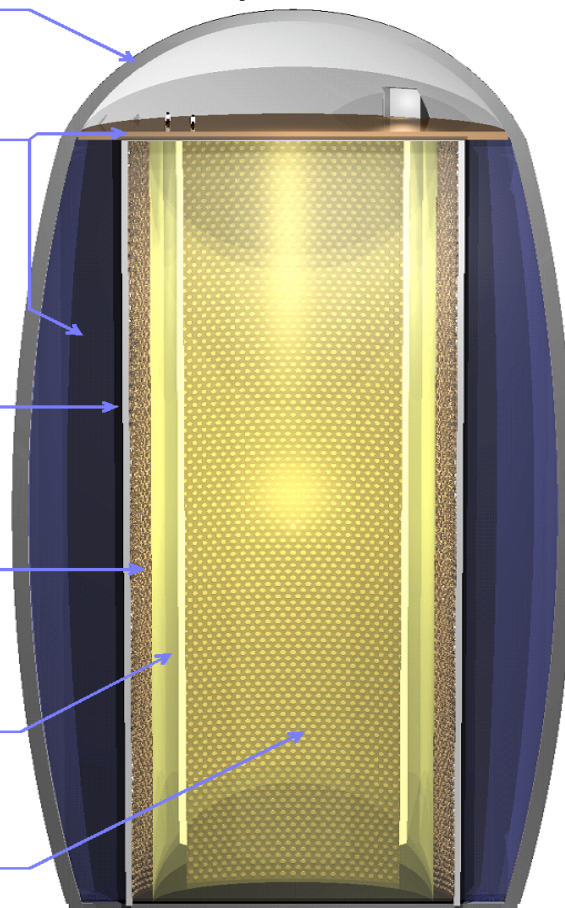

Borexino (LNGS):
LSci fiducial/tot vol.: 100/300 t
Buffer UP-org/water: 1k/2.4k t

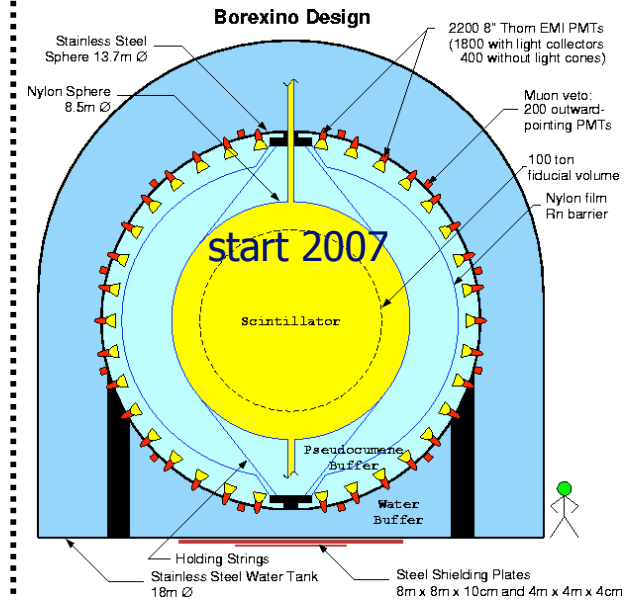

KamLand (Kamioka):
LSci fiducial/tot vol.: 400/1k t
Buffer UP-org/water: 2k/3k t

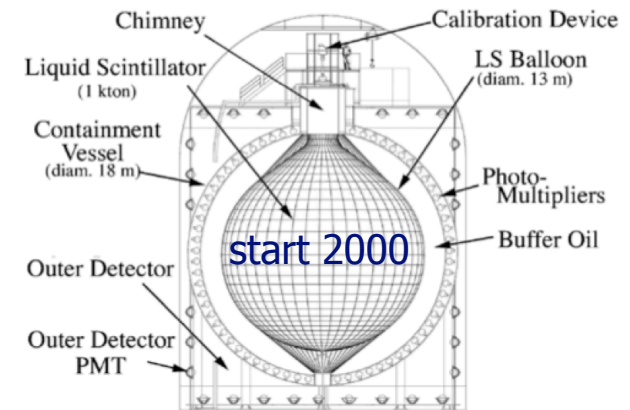

Liquid Argon \Rightarrow GLACIER

- ~ 100 kt
- LAr storage based on LNG tank tech.
- Double - Phase LEM readout (gain $\sim 10^4$)
- Cockcroft-Walton (Greinacher) Voltage Multiplier (~ 1 kV/cm)
- Very Long drift distances (~ 20 m !!)

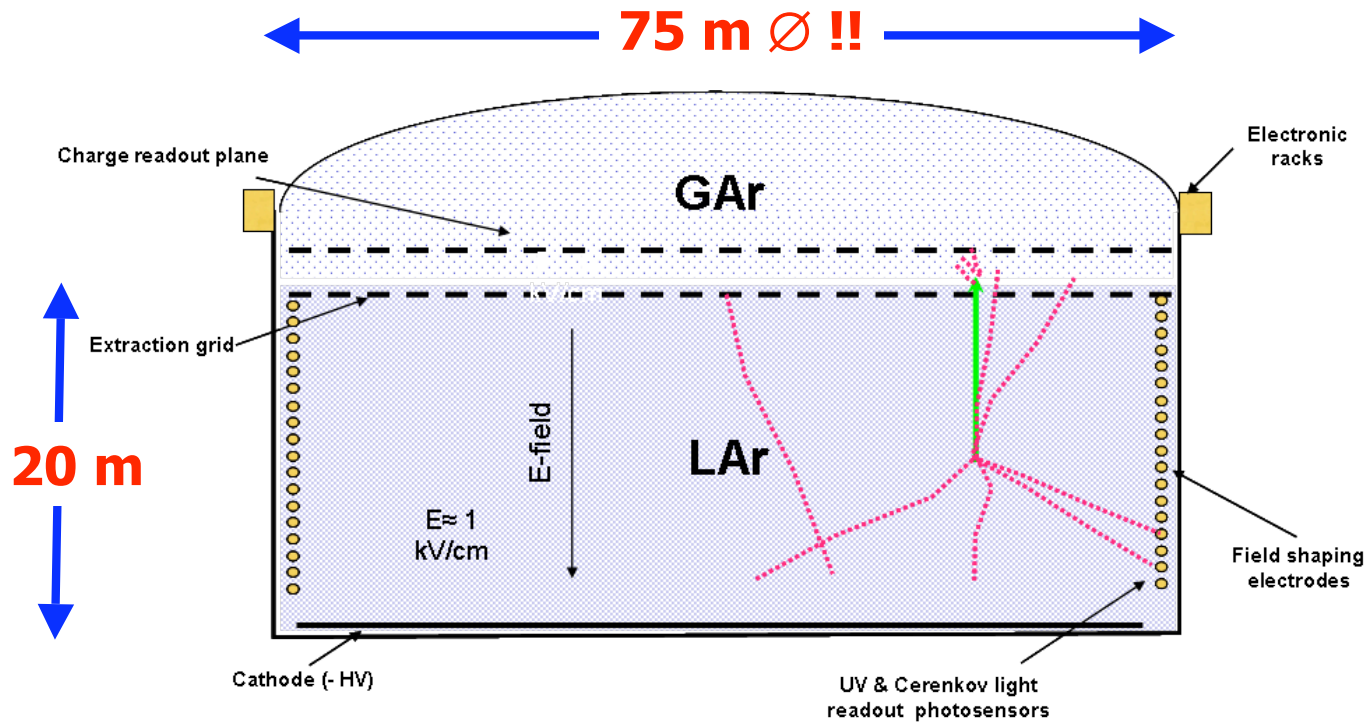

“Precursor”
ArDM (LSC ?)
1 t LArg

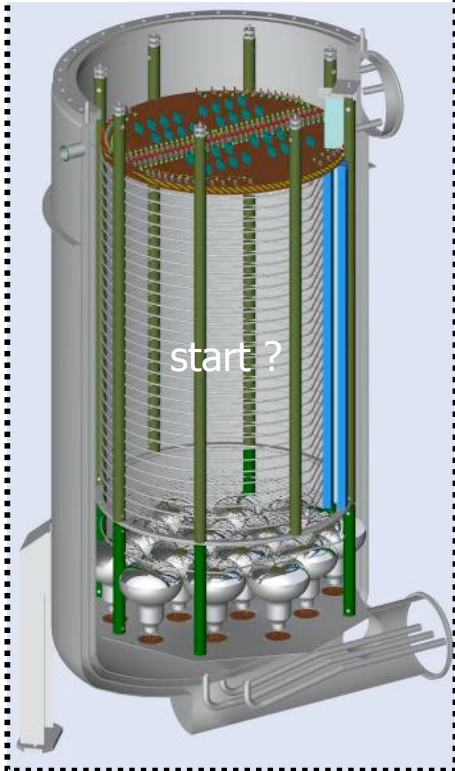

Rough Comparison of Potentialities:

Table 12. Summary of the physics potential of the proposed detectors for astroparticle physics topics. The (*) stands for the case where gadolinium salt is added to the water of one of the MEMPHYS shafts.

D. Autiero et al.; JCAP11(2007)011

Topics	GLACIER 100 kton	LENA 50 kton	MEMPHYS 440 kton
Proton decay			
$e^+\pi^0$	0.5×10^{35}	—	1.0×10^{35}
$\bar{\nu}K^+$	1.1×10^{35}	0.4×10^{35}	0.2×10^{35}
SN ν (10 kpc)			
CC or inverse β	$2.5 \times 10^4(\nu_e)$	$9.0 \times 10^3(\bar{\nu}_e)$	$2.0 \times 10^5(\bar{\nu}_e)$ (*)
NC	3.0×10^4	3.0×10^3	—
ES	$1.0 \times 10^3(e)$	$7.0 \times 10^3(p)$	$1.0 \times 10^3(e)$
DSNB ν (S/B 5 yr)	40–60/30	9–110/7	43–109/47 (*)
Solar ν (evts. 1 yr)			
^8B ES	4.5×10^4	1.6×10^4	1.1×10^5
^8B CC	—	360	—
^7Be	—	2.0×10^6	—
pep	—	7.7×10^4	—
Atmospheric ν (evts. 1 yr)	1.1×10^4	—	4.0×10^4 (1 ring only)
Geo ν (evts. 1 yr)	Below threshold	≈ 1000	Need 2 MeV threshold
Reactor ν (evts. 1 yr)	—	1.7×10^4	6.0×10^4 (*)

⇒ “~ similar” physics output in “~ similar” periods of time

We **must** bear in mind, always, a possible new ν beam, of some kind, from CERN

⇒ what is θ_{13} ?



Feasibility Study for
Laguna at the LSC

Some items about this first period **LAGUNA-LSC**

- The coordinator of the **Feasibility Study (FS)** for the **LSC** is L. Labarga (**UAM**); he has the help of **LSC** staff
- For the **FS**, LAGUNA-EU assigned ~145 K€ to the **LSC**, and 31 K€ to the **UAM**, the **LSC** and **UAM** contributed with ~100 K€ and 7 K€ respectively (the later from the AC FPA2008-03002-E)
- The **LSC** has not Geotechnic Dept.; technical part had to be subcontracted
- July 2008 --> March 2009
 - Contact, discussions and (private) pre-selection of Geotechnic Companies candidate to carry out the **FS** for the **LSC**
 - Administrative and legal procedure to select the Company.
 - Select Company (got a "*dream team*", see next slide), sign contract, Company starts working
- February 2010: The Company delivers the main document basis of WP2's "*Interim Report for the LSC*" (almost final version, yet **preliminary**, is at <http://www.lsc-canfranc.es/> links *activity* → LAGUNA)

Main work
Help work

PROJECT TEAM

leader: *Manuel Romana* (STMR)

co-leader: *Clemente Saenz* (Iberinsa)

Companies involved:

LAGUNA Canfranc feasibility study

- **Iberinsa: big Spanish consulting firm**
 - Geological-geotechnical work (General)
 - Numerical modelling
 - Environmental questions
 - Auxiliary installations. Buildings
 - Cost estimates
- **STMR: small Spanish geotechnical and tunnelling firm**
 - Project managing and coordination
 - Geologic-geotechnical work (Rock Mechanics problems)
 - Construction processes and work methods
- **Obras Subterranas (OSSA): Biggest Spanish firm for underground works construction**
 - Construction processes and work methods
 - Cost estimates
- **Itasca Spain: Local branch of Itasca network of firms**
 - Numerical modelling
- **Individual consultants**
 - Site knowledge (project and construction Manager for Somport Tunnel)
 - Tectonic stresses and seismicity (Madrid Geology Faculty Professor)

General I:

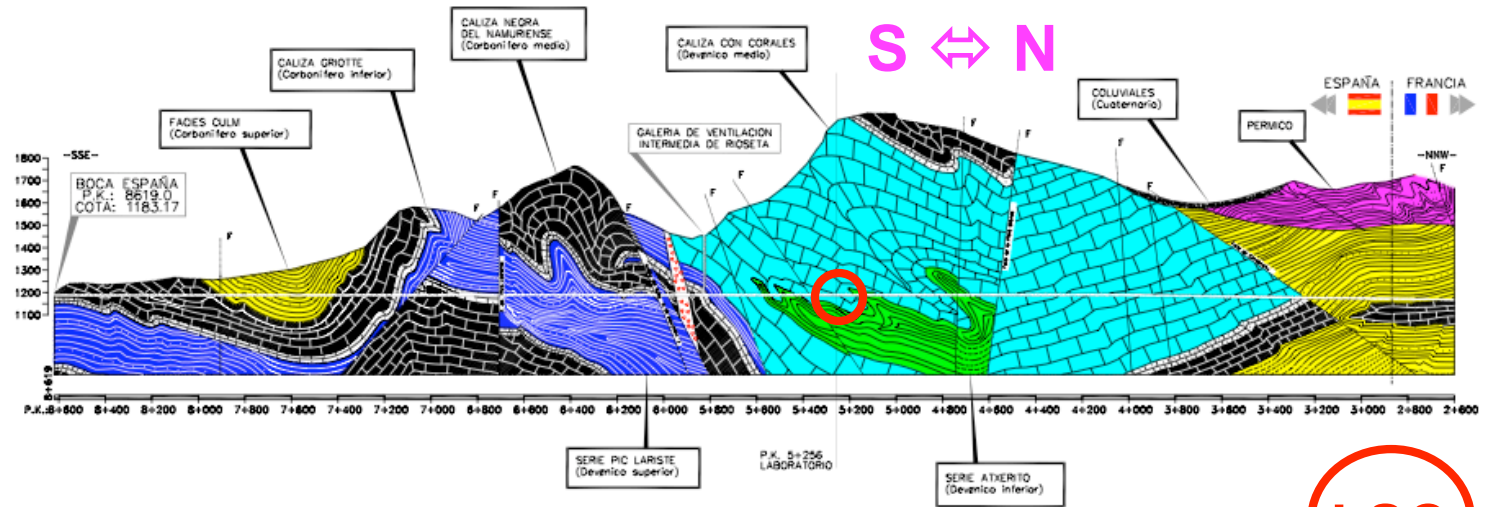

best compromise between overburden, rock quality, knowledge (within FS) and expectations of rock quality, centralization of services ... :

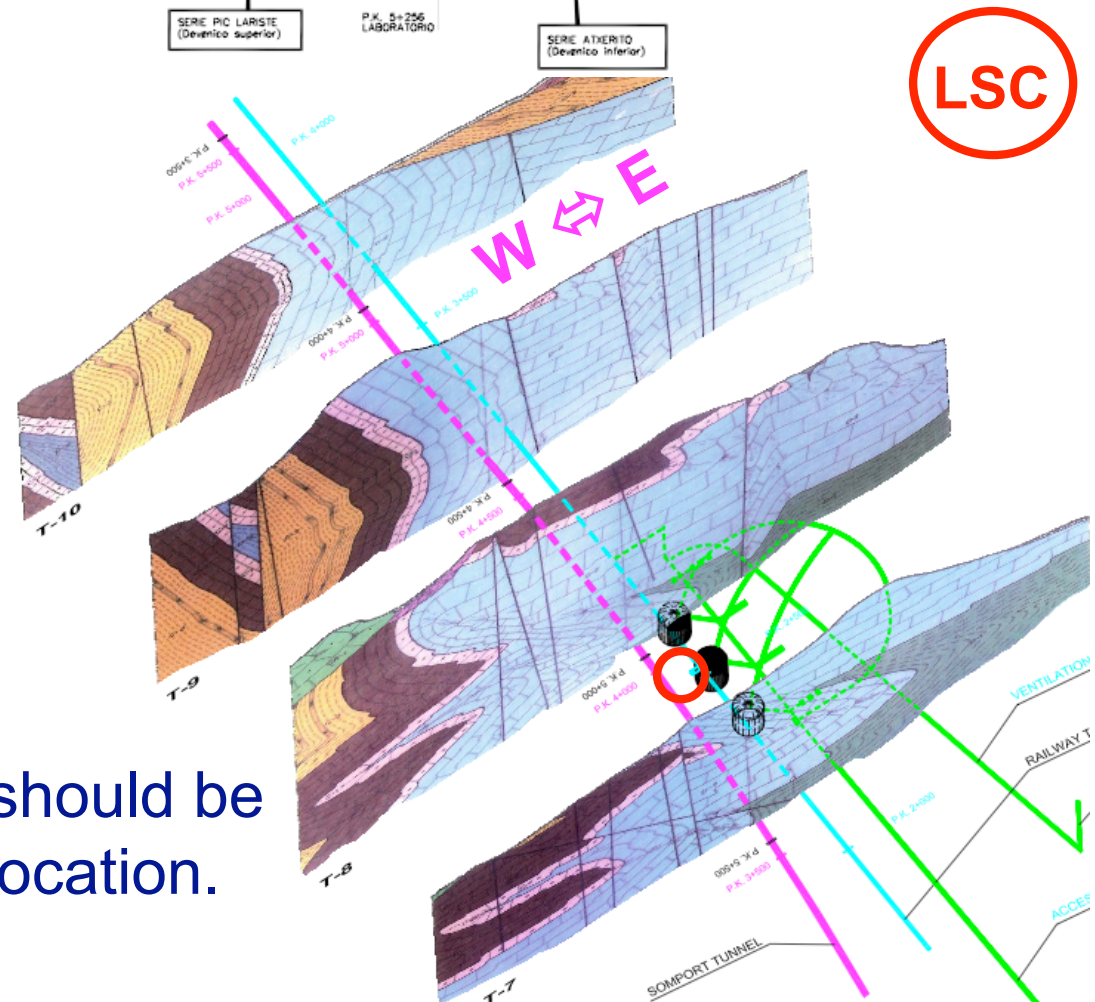

⇒ the LAGUNA experiment should be close to the current LSC location.

General II:

⇒ place **MEMPHYS** and **LENA** where overburden is largest

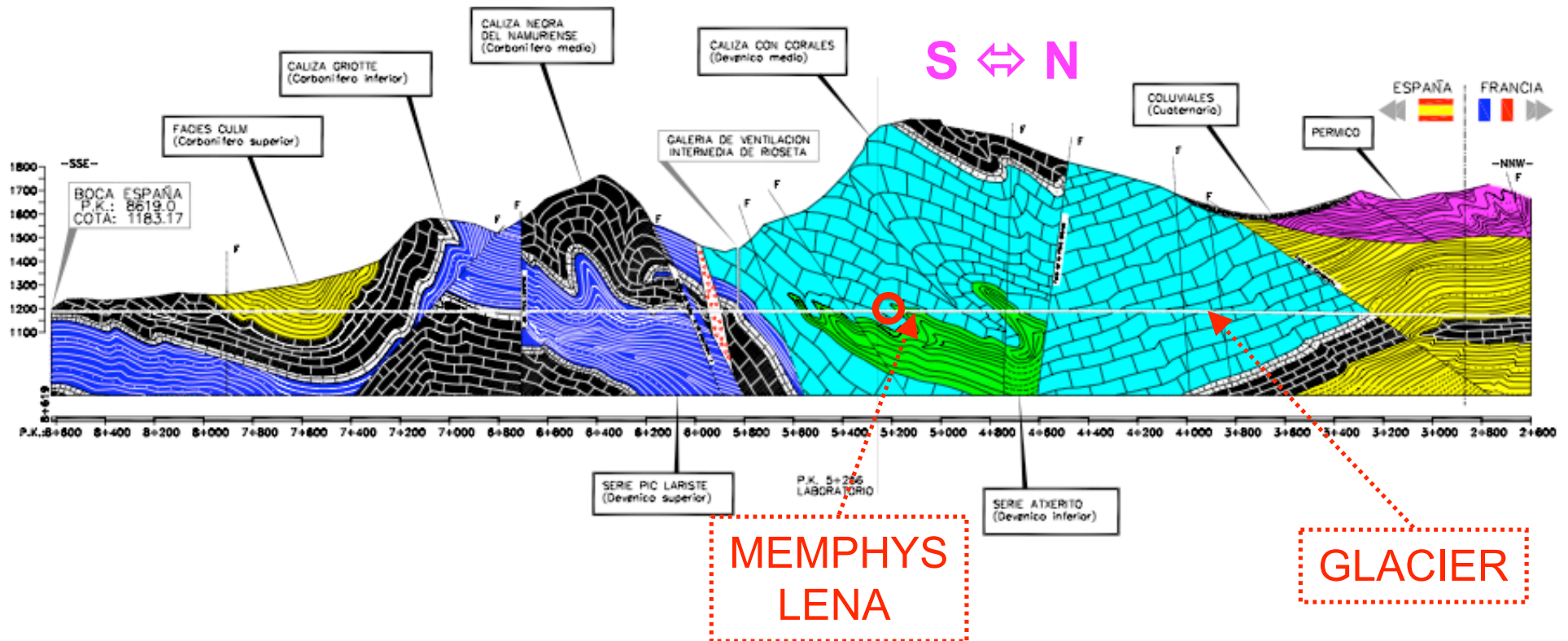

- **GLACIER** can work at shallower locations.
- Its 75 m \varnothing dome (!) is a geotechnic challenge; less overburden and best rock quality will be of big help.
- There is a region along the tunnel shallower and of better rock
 - ⇒ place **GLACIER** there

Important reminder

The LSC lies physically in between:

a New Road Tunnel (Somport tunnel, opened 2003)

- binational: Spain (Jaca) - France (Pau)
- Length: 8,6 Km (5,7 in Spain + 2,9 in France)
- State of the art on safety features (EU directive 2004)

an Old Railway Tunnel

- Now used as service and emergency exit of Road Tunnel
- Safety galleries connecting both tunnels every 400 m
- Current Access for Laboratory

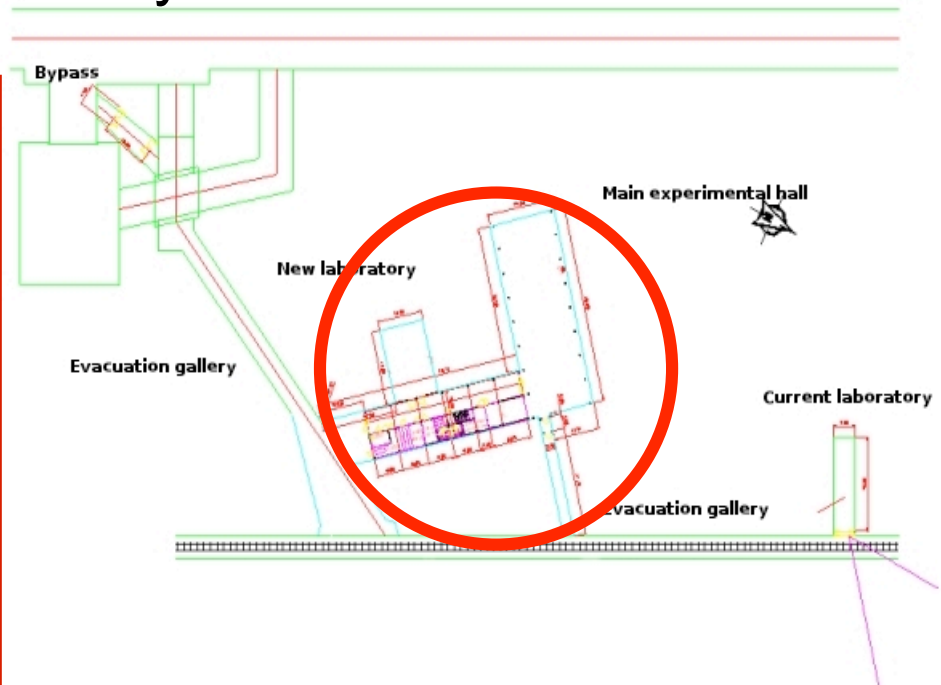
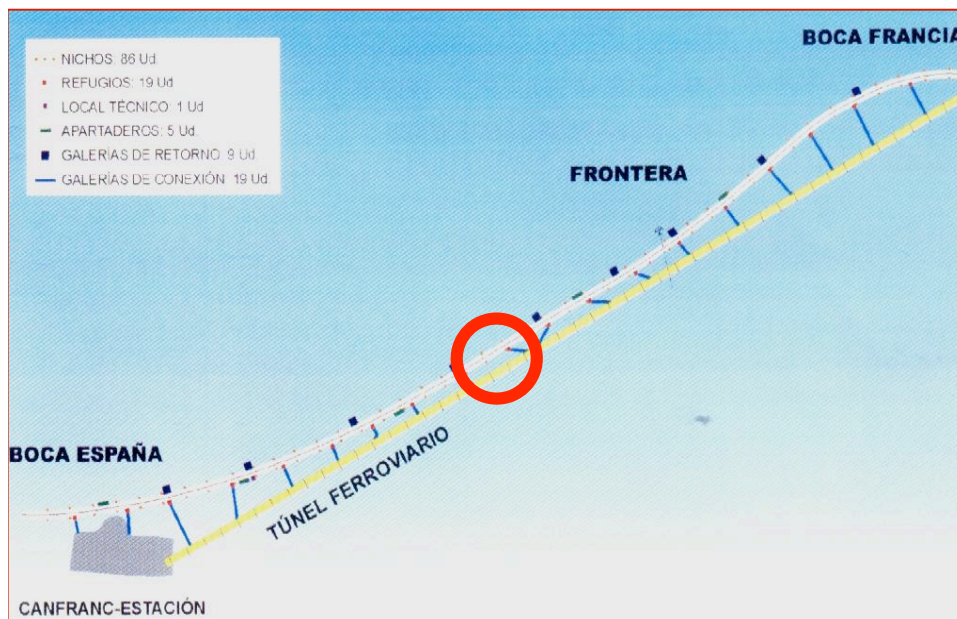

General III:

- The main layouts in the three experiments have been designed neither to interfere with the regular running of **Road Tunnel** nor with the emergency and service purposes of **Railway Tunnel**.
 - Of course they try to take the maximum profit of them, but at the same time they are thought to operate independently if necessary.
- ⇒ An **independent access tunnel** (2 - 3 Km long, ~ 4 - 7% downwards) almost parallel to existing ones
- For construction access (!)
 - For regular operation/running and maintenance access
 - For radon-free air conduction
 - For supplies: energy, water, others
 - For Liquid Scintillator .OR. Liquid Argon supply by truck
 - For ventilation: regular operation/running and fire
- ⇒ A **permanent connection** with the **Road** and **Railway tunnels** and the **LSC**
- For normal operation (connection to **LSC**)
 - As an emergency escape way
- ⇒ Another **tunnel + vertical shaft** to the surface
- For ventilation: regular operation/running and fire

For instance **MEMPHYS**

Railway Tunnel

Connection to Tunnel + LSC

Tunnel + Vertical Shaft to surface

Road Tunnel

Independent Access Tunnel

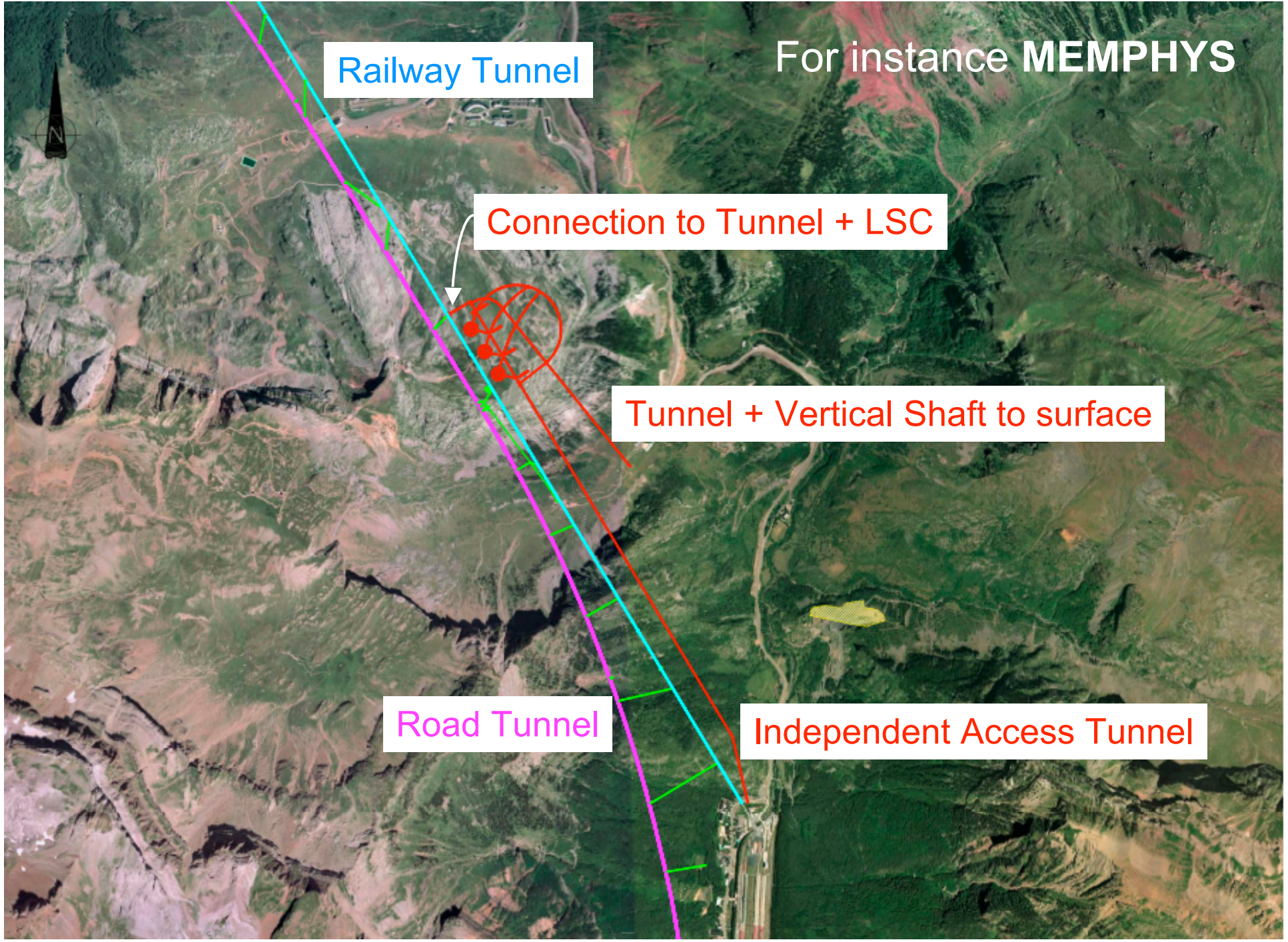

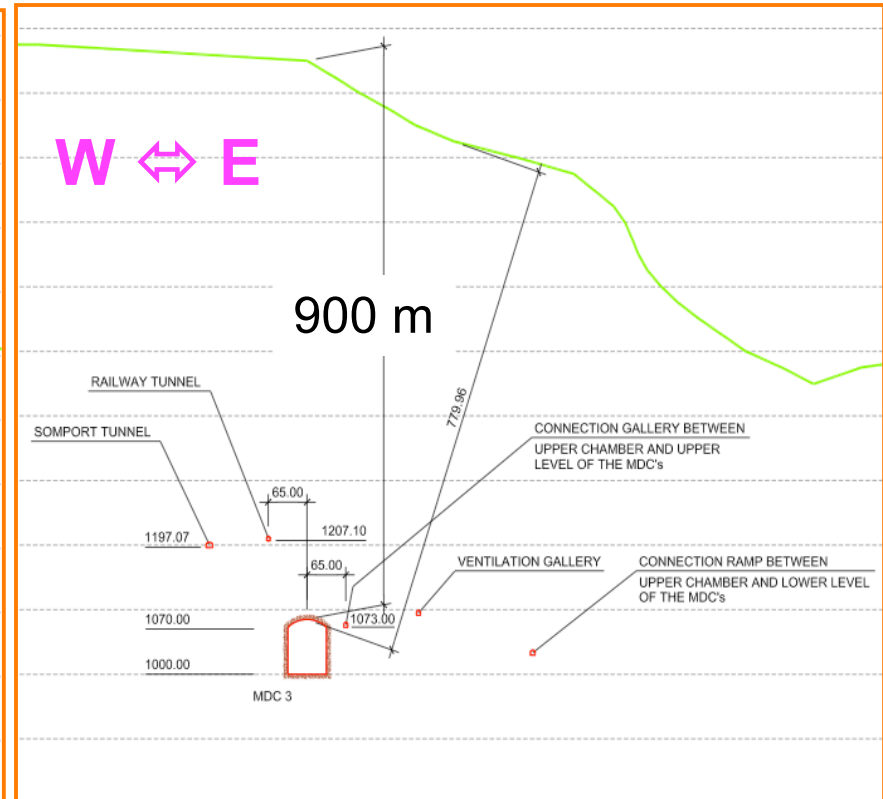
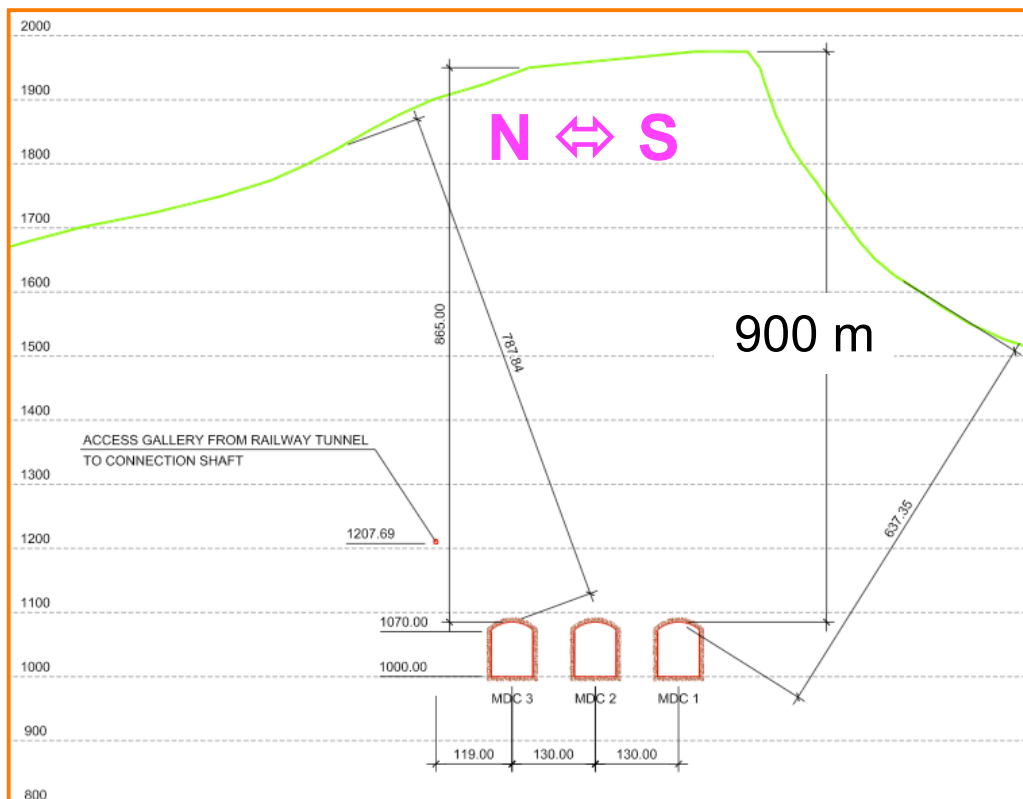
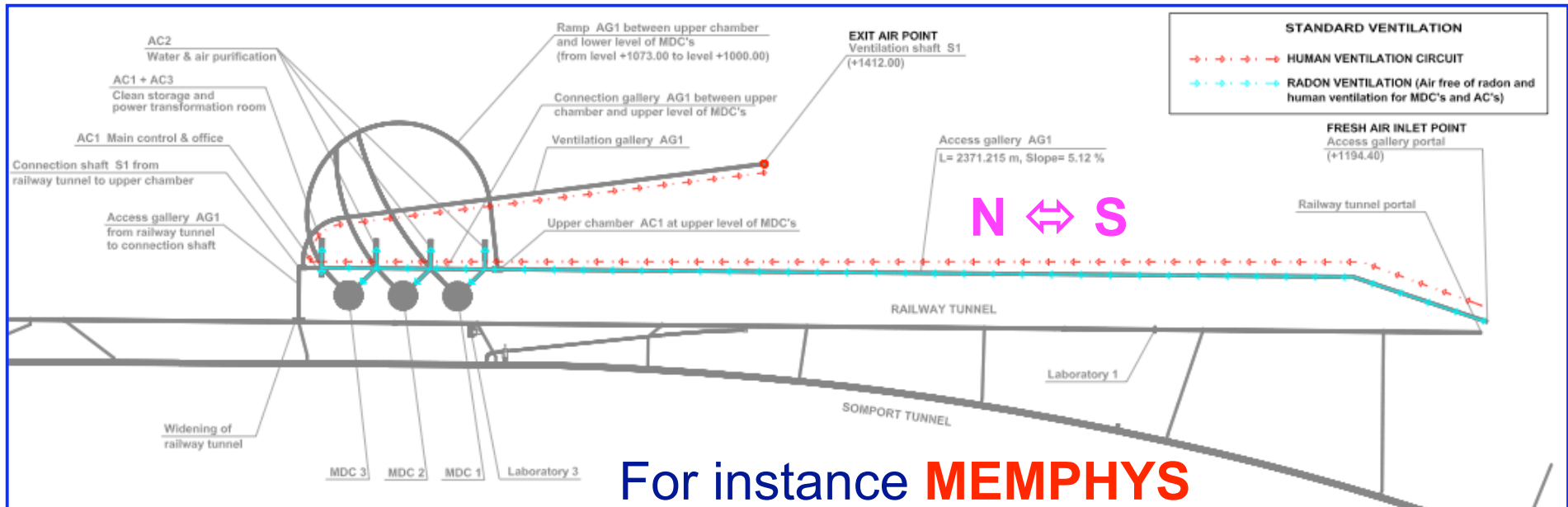

Environmental I:

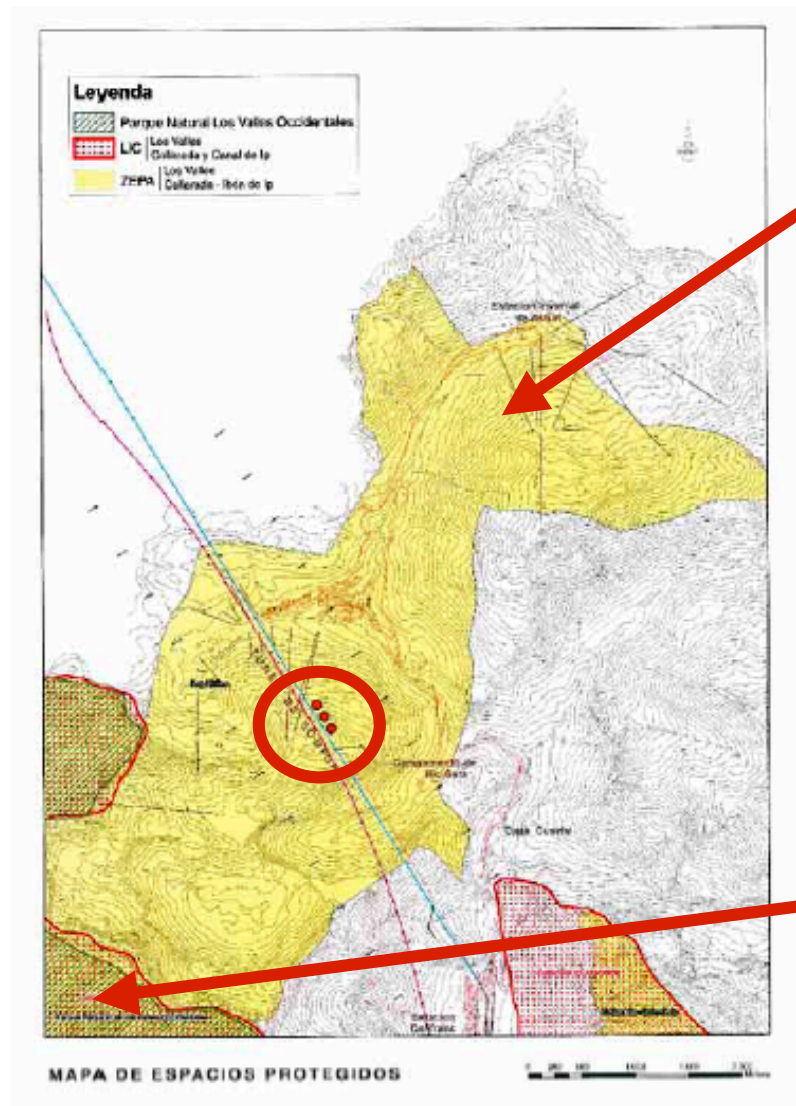

Nearby protected sites

- Special protected area for birds (ZEPA)
 - Includes site
 - There is a rare vulture protected species
 - No influence for underground works
 - Regulations for surface works during birds nesting period
- Nature Park
 - Far away from the site

LIC ≡ SCI, Spaces of Community Importance; ZEPA ≡ SPA, Special Protection Areas (Birds); Parque Natural ≡ Nature Park

Environmental II:

Animals habitats network

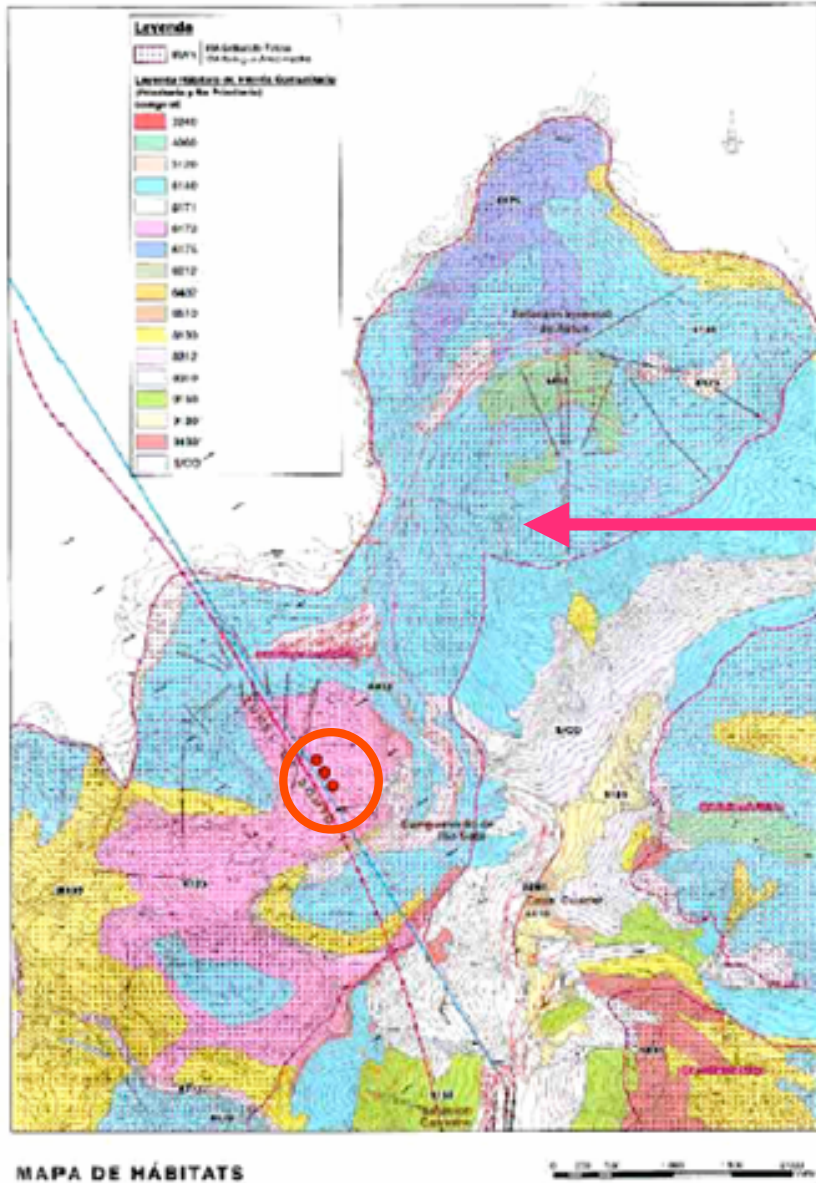

- Maps for animal and vegetal habitats network around the site have been drawn
- There is no special problem at the site for underground works

Environmental III:

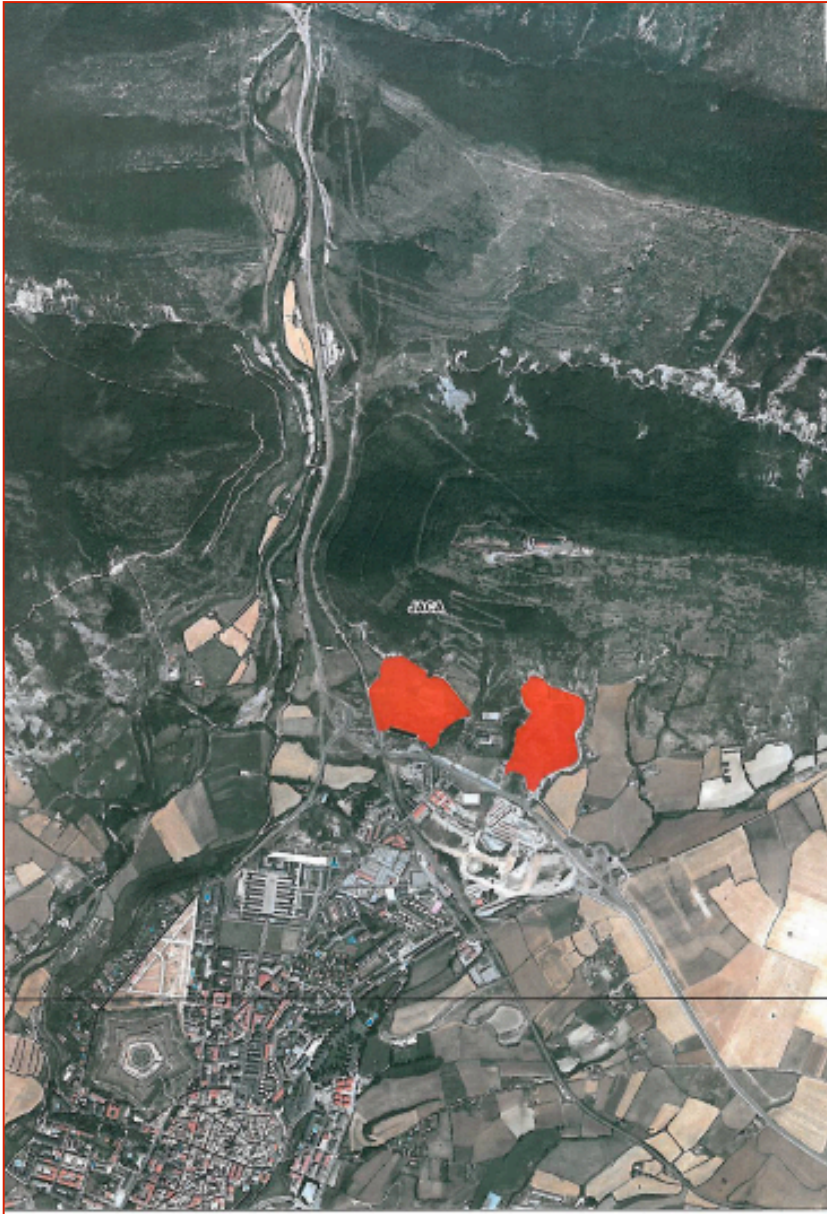

Places for waste rock

Waste rock quantities are big

MEMPHYS ~1.000.000 m³

GLACIER ~200.000 m³

Two sites are selected closer than 20 Km. with no environmental problems

The places would be reforested like it was done for the **Road Tunnel** waste rock sites

Geology I: profile at site from Road Tunnel studies

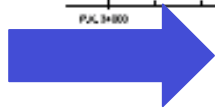
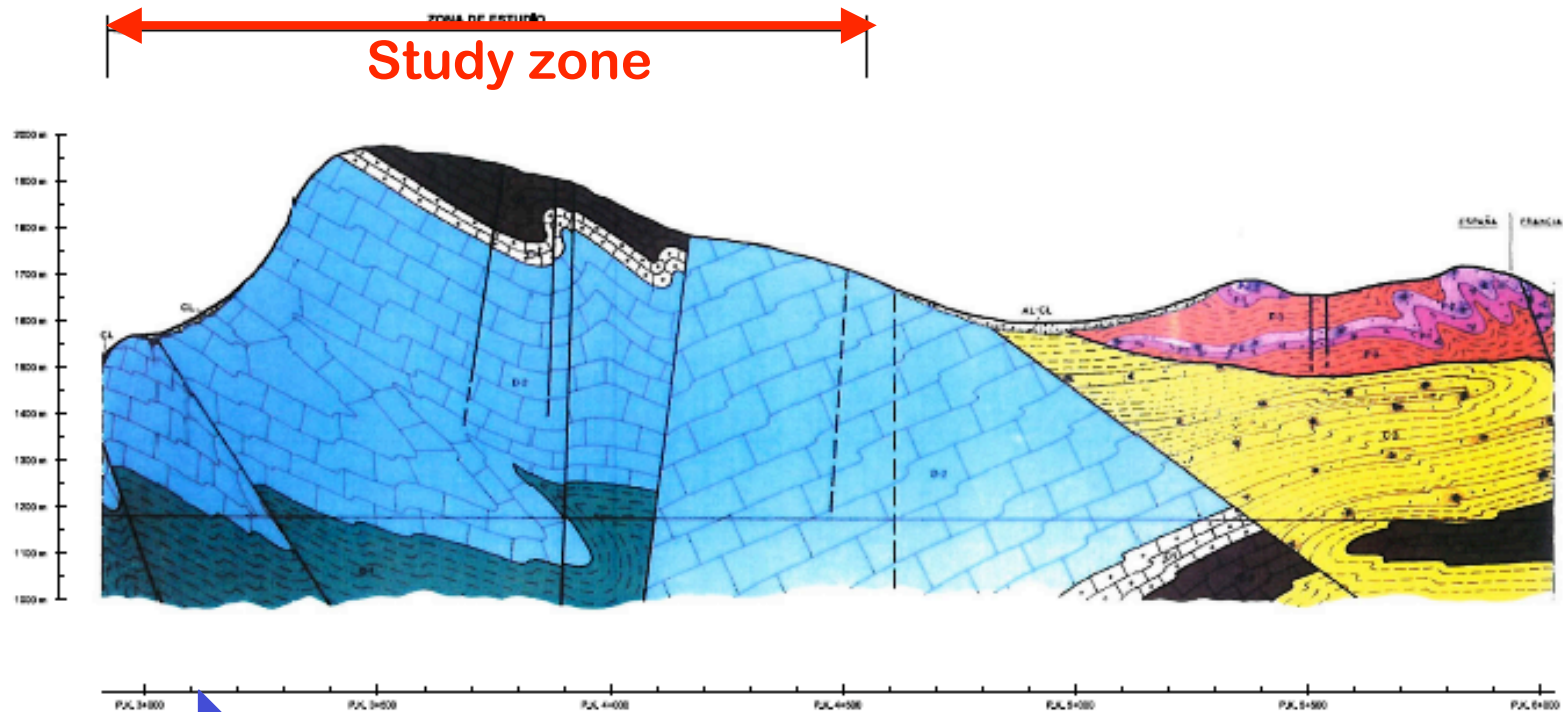

- Calcareous slate (**Atxerito series**) **LSC**

- Metamorphic (low grade)
- Schistose texture



- Limestone (**Coralline limestone Series**)

- Sedimentary
- Bedded texture

Geology II: geological studies in this FS

- Retrospective analysis of falls in the current LSC in order to check the real rock parameters around the laboratory
- Revision and analysis of geological data gathered at Road Tunnel excavation fases
- Two probing boreholes (40 and 70m long) in key locations
- Laboratory tests

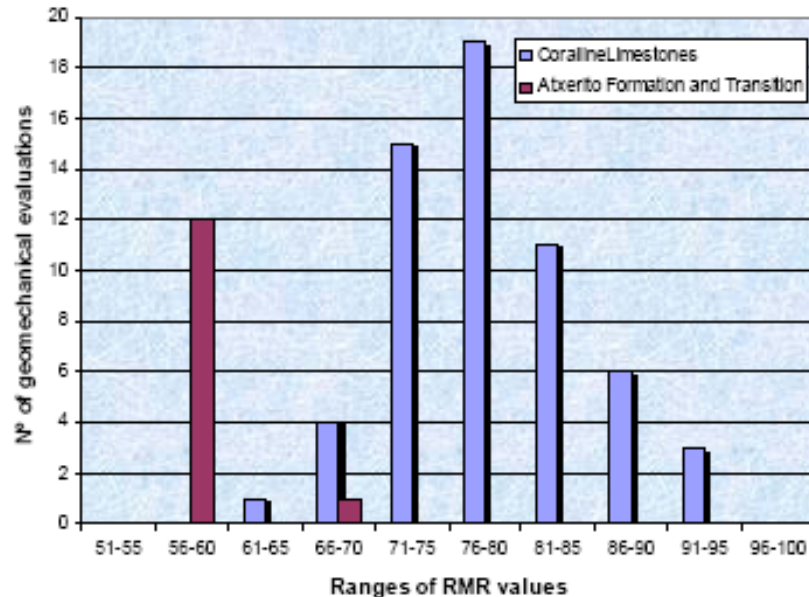

Two boxes of S-1. At left, from 11,00 to 13,25 meters deep. At right, from 37,00 to 39,20.

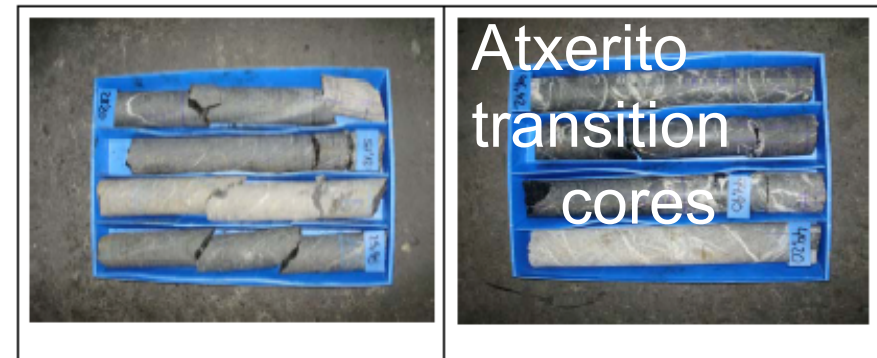

Two boxes of S-2. At left, from 25,90 to 28,20 meters deep. At right, from 44,20 to 46,420.

Geology III: conclusions and assumptions for calculations

- The rock in most of the site is good quality marine coralline limestone
- There is a transition between the limestone and medium quality folded Atxerito beds
- The distribution of both rocks is well known at the **Road Tunnel** elevation (both from tunnel excavation and further studies for **LAGUNA** project)
- To know the exact distribution of both rocks at larger depths it is necessary a further campaign of geological-geotechnical boreholing

The rock assumptions for the calculations of this study are:

- **MEMPHYS** and **LENA** are assumed to lie in the worst possible situation (the Atxerito beds)
- **GLACIER** is known to lie in good quality limestones beds

Conceptual support design I: MEMPHYS and GLACIER

There are *no precedents*

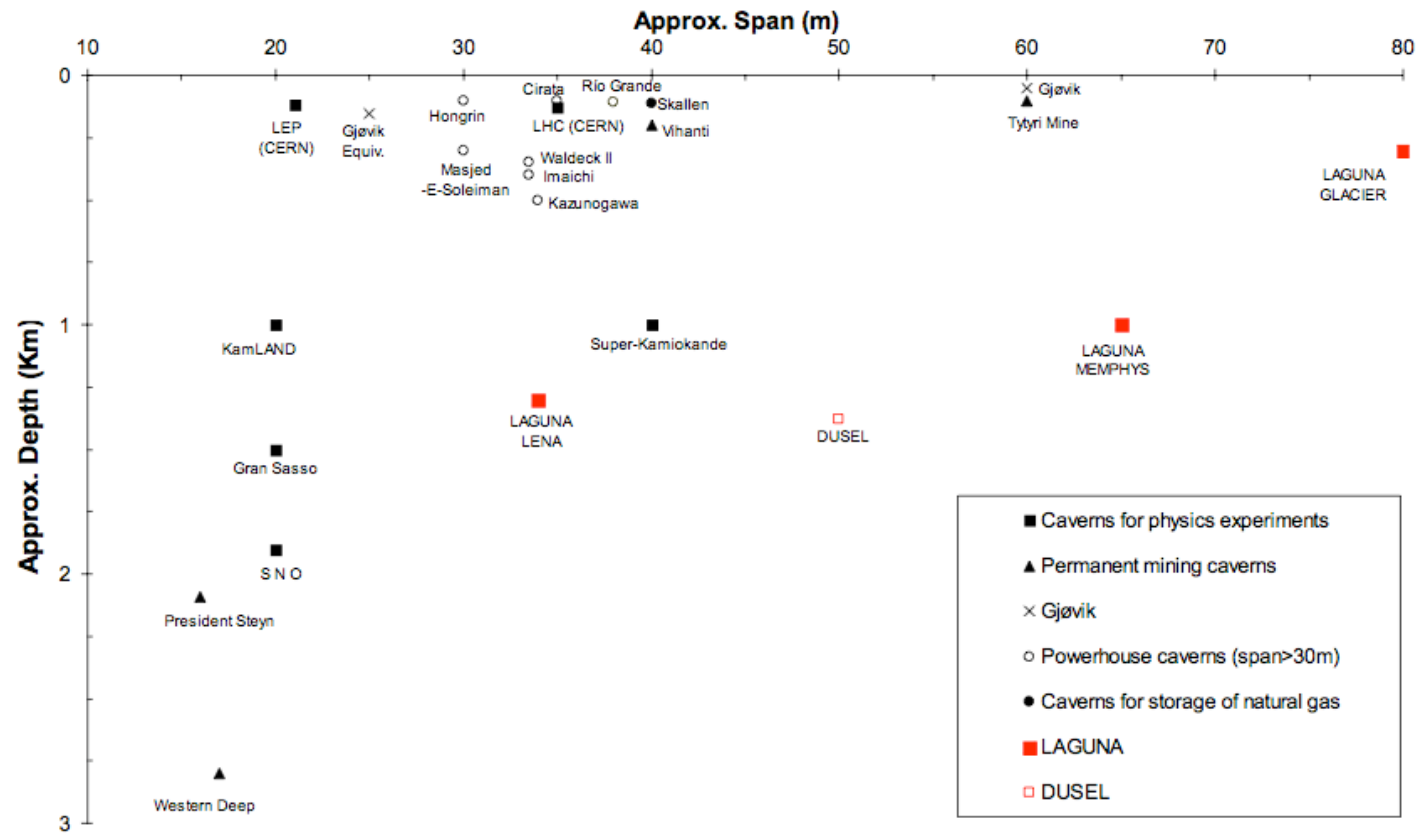

Figure 3.1-5. Scattered plot span vs. depth of permanent large caverns classified by use.

M. Romana: *“we are dealing with world record stuff”*

Conceptual support design I: MEMPHYS and GLACIER

There are *no precedents*

Their big spans cannot be supported by conventional methods (cables < 20 m, bolts, shotcrete):

- Able to cope with rock stresses near excavation limits
- Able to cope with “minor” wedges (relative to big spans)
- Not able** to cope with “major” wedges

A complete concrete roof vault is not considered

⇒ Go for a **partial concrete structure** to cope with eventual big wedges

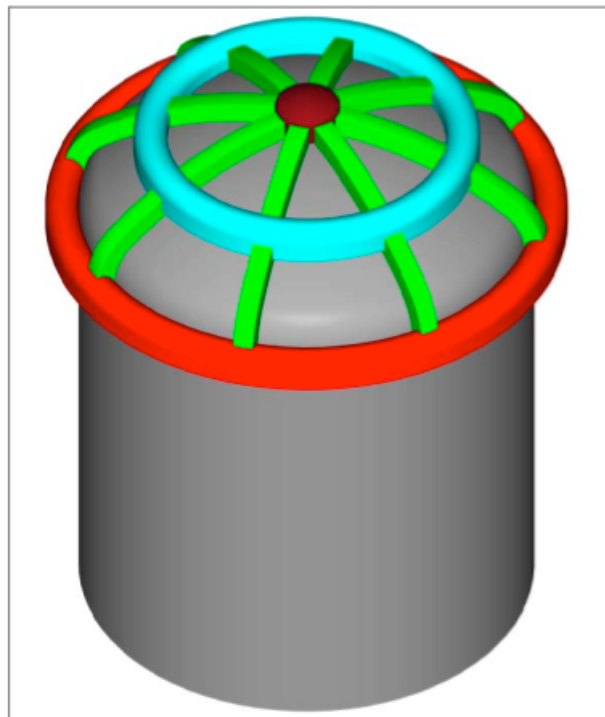

Figure 7.3-2. Perspective view of the vault system.

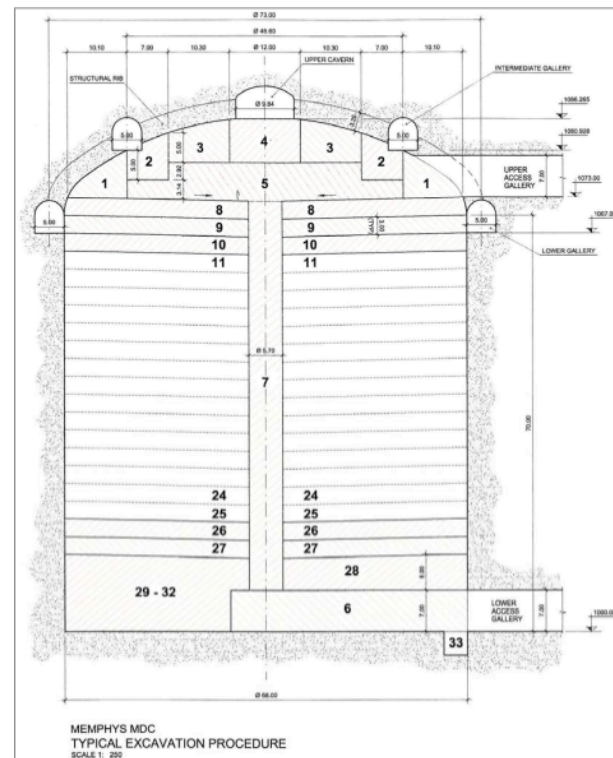

Figure 7.3-3. Excavation sequence for the MEMPHYS caverns.

Conceptual support design II: LENA

There are precedents: **Mingtan** cavern in weak rock (by *Hoek*)

1. Preliminary circular gallery excavated over the cavern
2. Support cables installed from the gallery before cavern excavation
3. Support completed with more cables, bolts and shotcrete during excavation

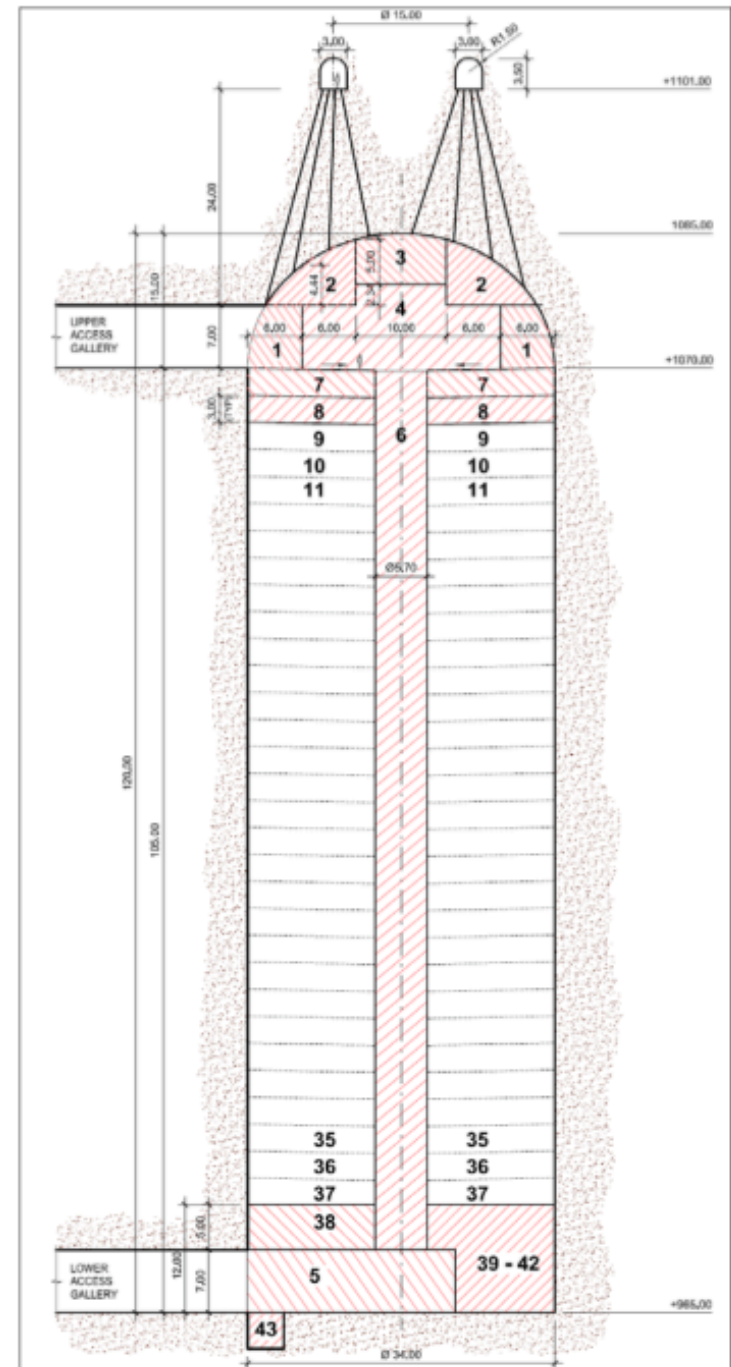
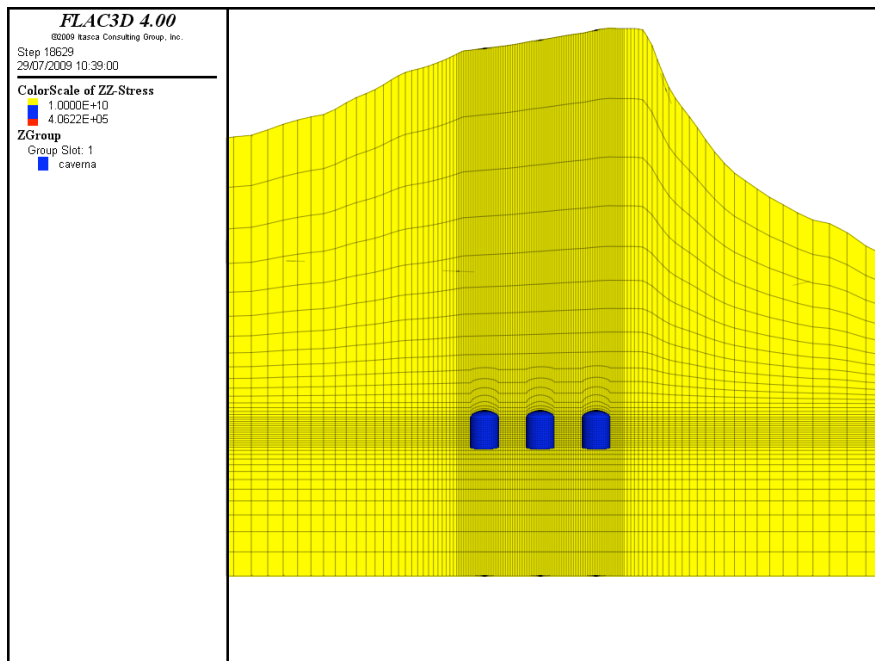
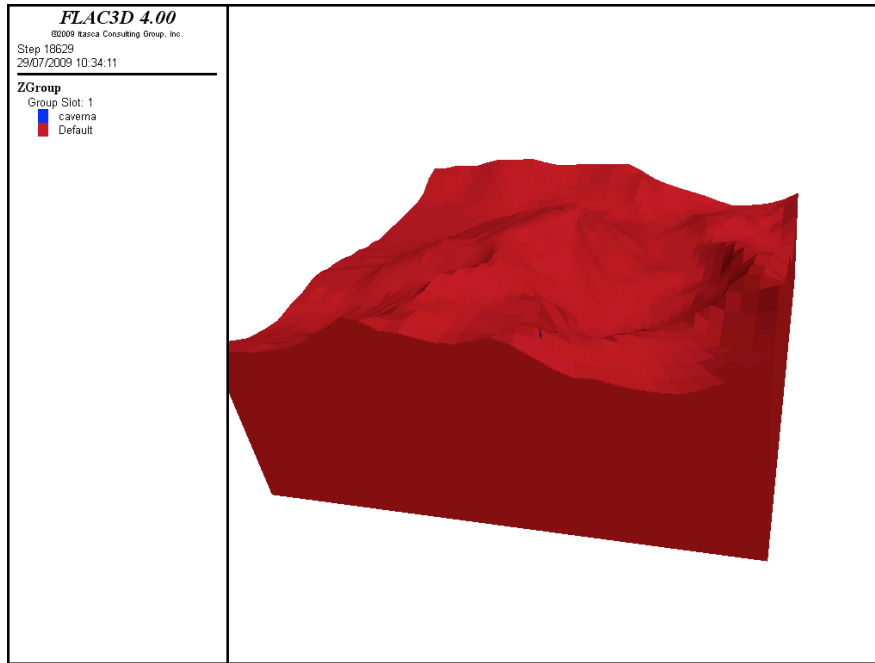

Figure 8.3-3. Excavation sequence for the LENA cavern.

First estimation of the caverns feasibility I:

Modelling / Calculations [elastic]



1. Check the effect of real topographic features

⇒ no significant effect

First estimation of the caverns feasibility II:

Modelling / Calculations [elastic]

2. Three MENPHYS caverns; Plasticity Indicators \Rightarrow OK

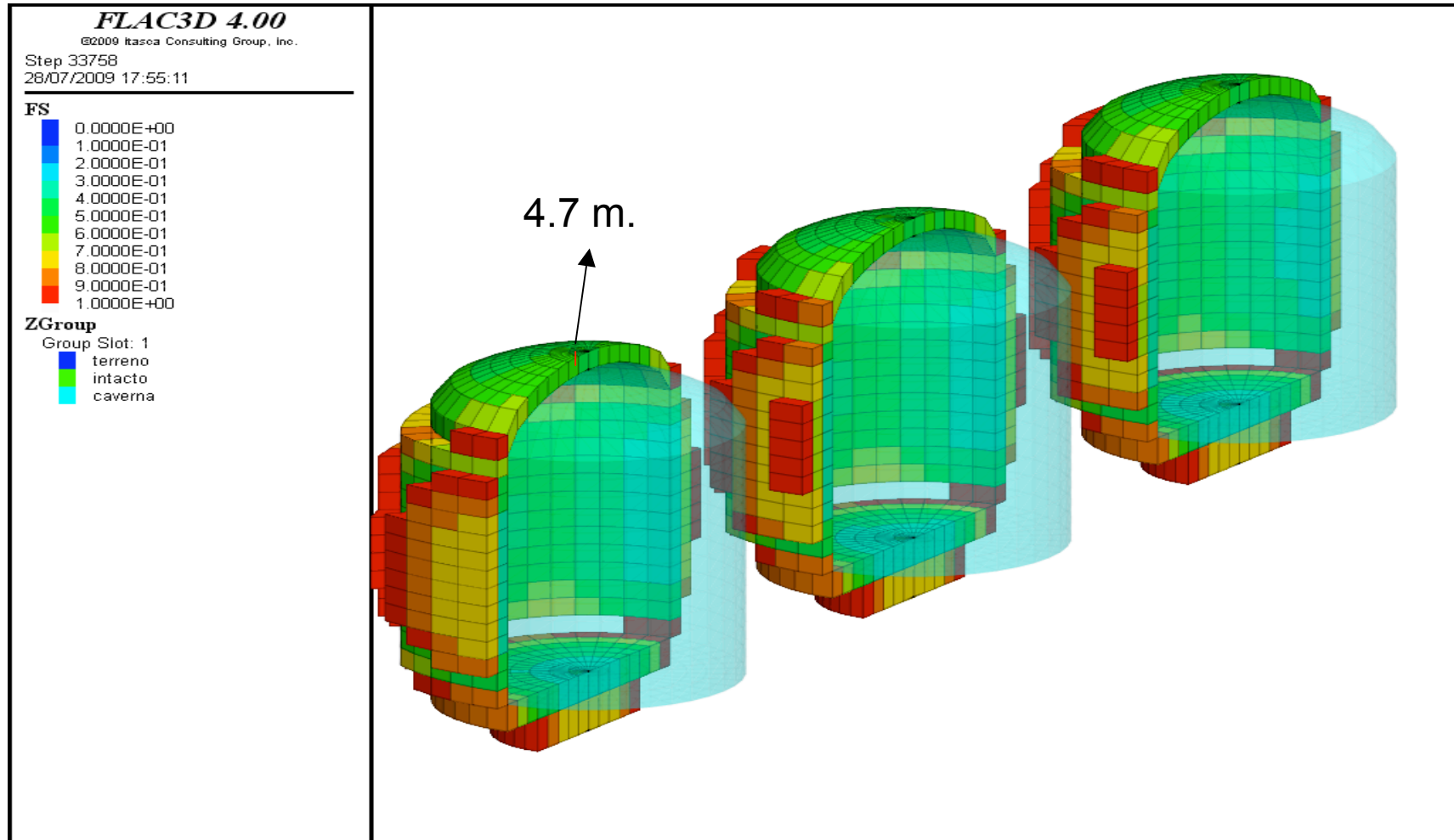

First estimation of the caverns feasibility III:

Modelling / Calculations [elastic]

3. enormous GLACIER cavern; Plasticity Indicators \Rightarrow OK

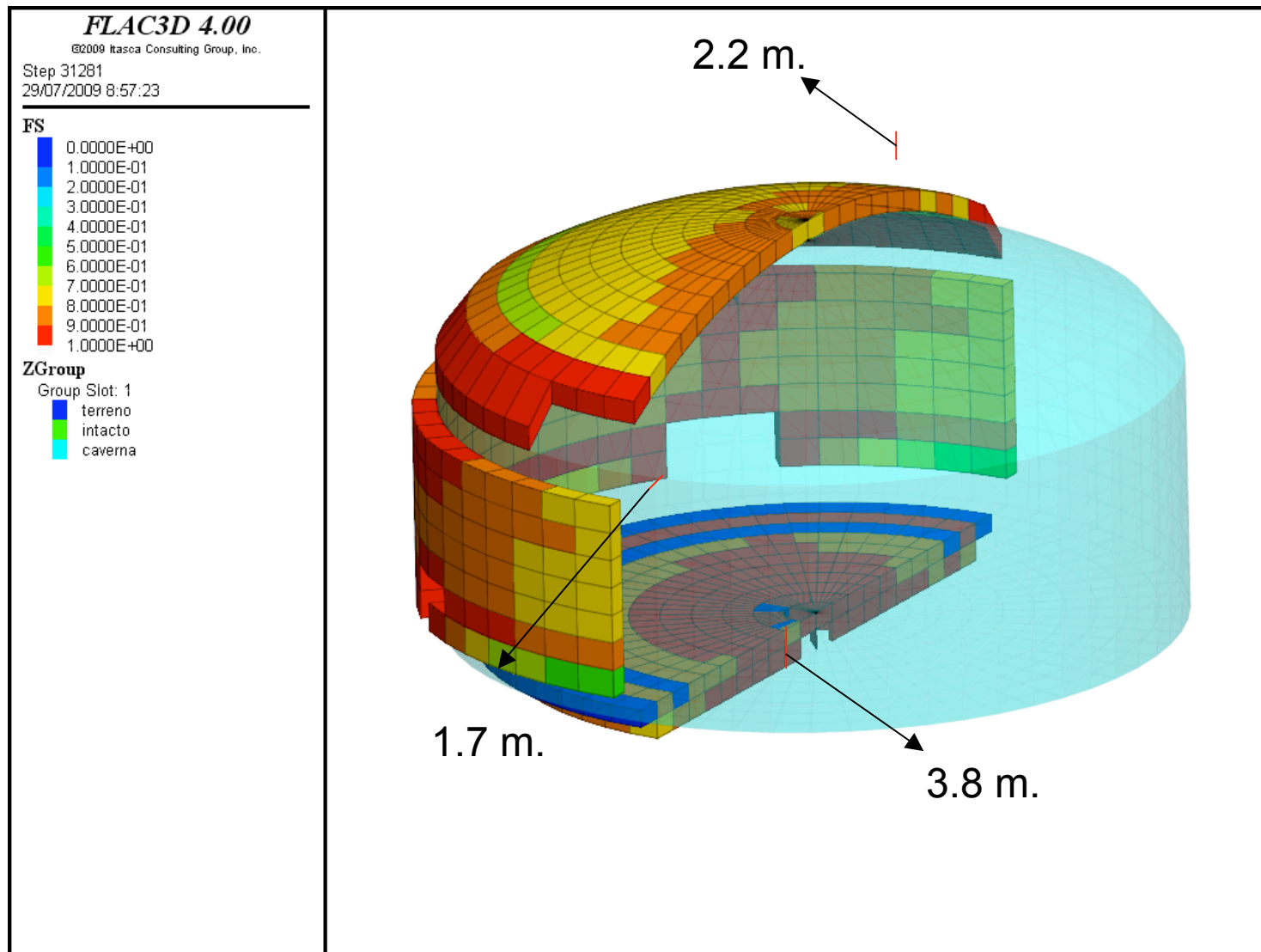

Realistic Calculation: MENPHYS elasto-plastic modelling

- Assumed worst rock conditions
- Almost all construction stages (slightly simplified)
- Three different behaviour laws for concrete
 - Elastoplastic
 - Brittle failure
 - Softening
- Two different concrete sequences
 - Prior to cavern excavation
 - By stages with cavern excavation
- Concrete needs some reinforcement in the roof lower gallery

Elastic modelling studies allows us to extrapolate valid conclusions for LENA and GLACIER pre-designs

Example for illustration follows:

Pre-design after elasto-plastic structural calculations of one of the three **MENPHYS** detector' caverns

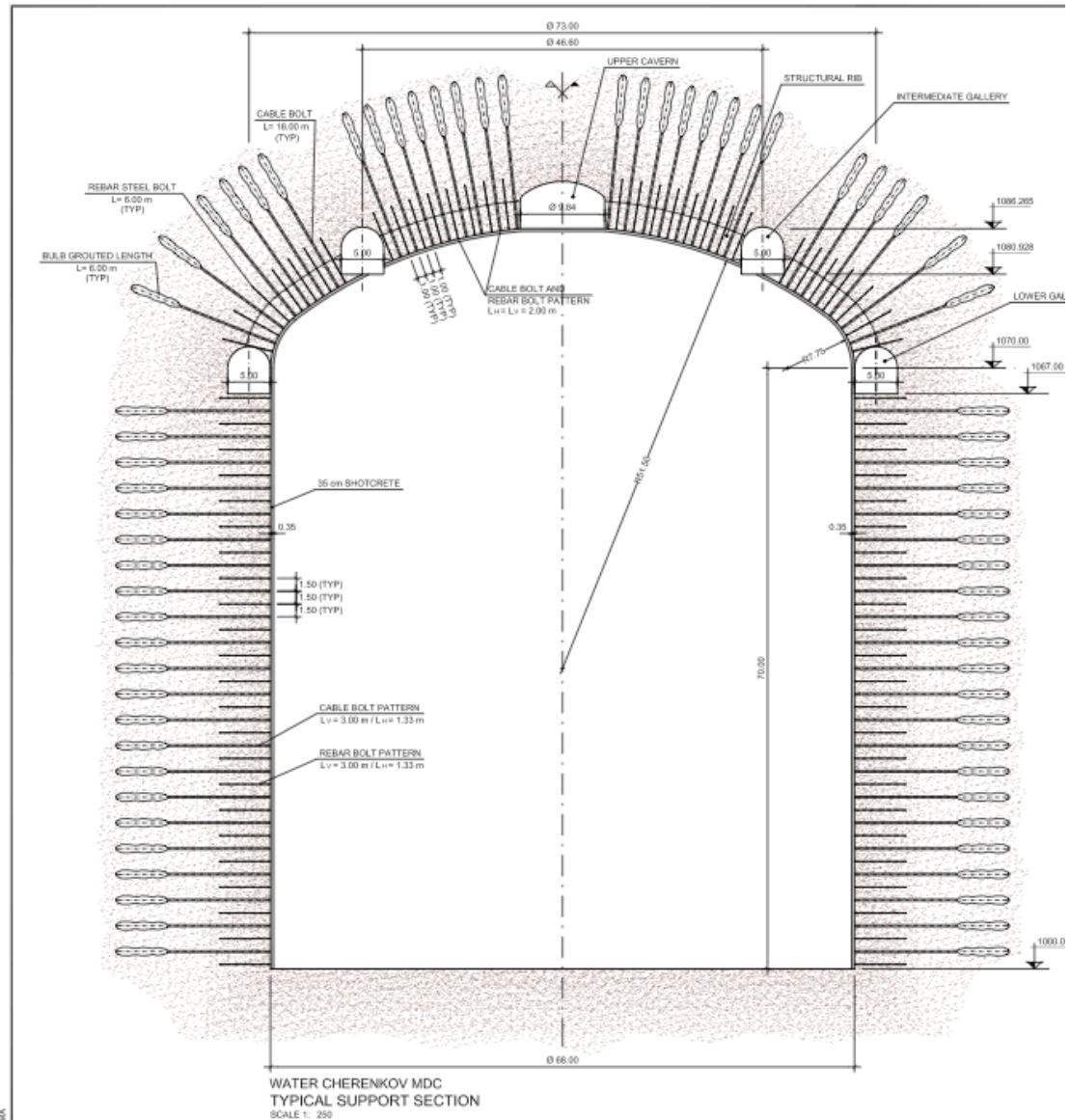
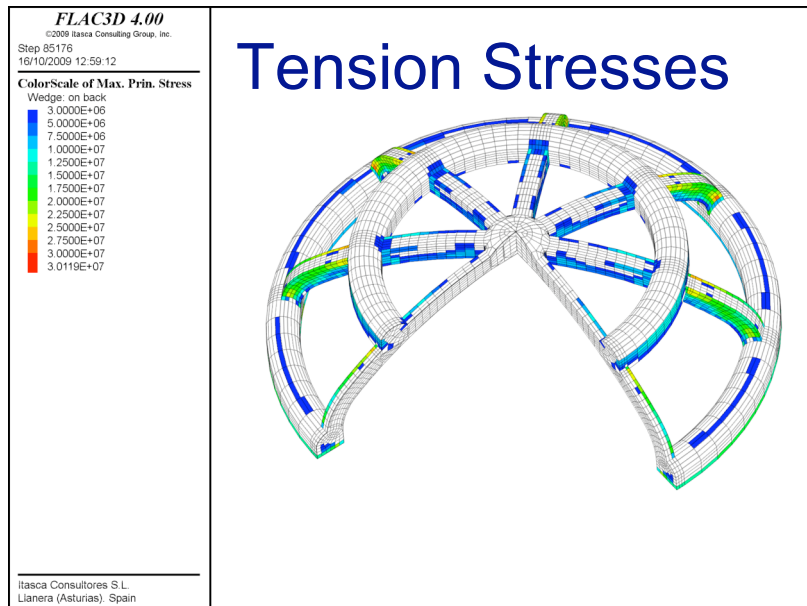
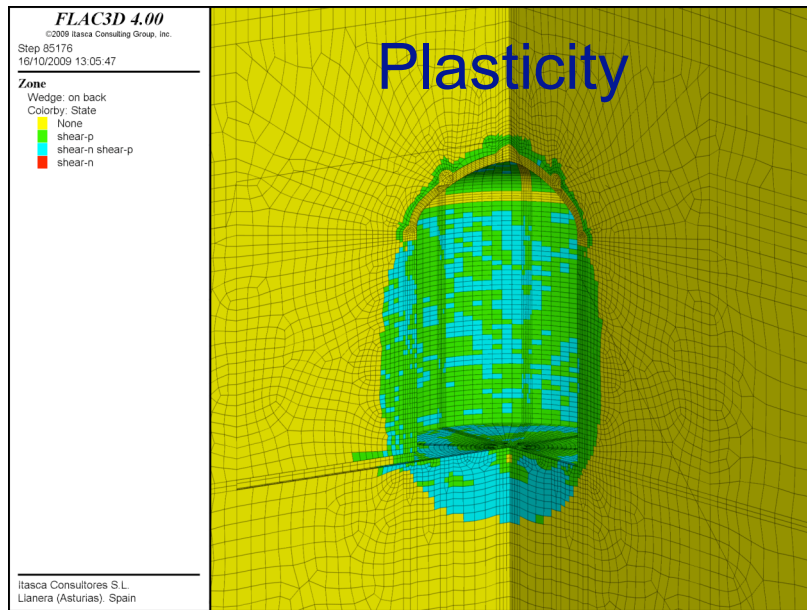

we even don't forget (try to) that part of
our day-to-day life is outside physics

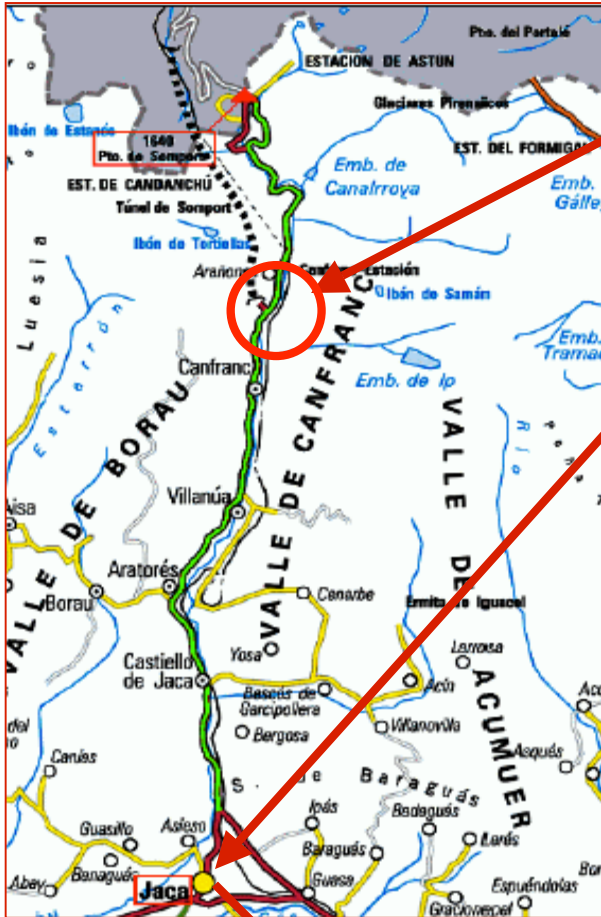

the LSC, candidate LAGUNA site, is in the middle-sized village of Canfranc

at 21 Km from the

old (~1097) but lively (~15000 inhab.) city of Jaca, that is well capable to provide all living services / needs

both with excellent road communications with all major Spanish cities, ports, airports etc.



also ...

technicians, admin. personnel, engineers, scientists, etc. may relax after duty in the two excellent **nearby** (< 3 Km) **sky resorts** **Candanchú** and **Astún**



How much would it cost ????

MEMPHYS

CHAPTER 1.- MDC EXCAVATION	
1.1 MDC EXCAVATION	70.600.064,33 €
1.2 MDC SUPPORT	40.095.860,77 €
PARTIAL CHAPTER 1 (euros)	110.695.915,10 €
CHAPTER 2.- ACCESS GALLERIES AND CAVERN EXCAVATIONS AND SUPPORT	
2.1 ACCESS GALLERIES	27.959.089,29 €
2.2 AUXILIARY CAVERNS	2.965.962,24 €
2.3 VENTILATION GALLERY AND SHAFT	7.301.460,87 €
PARTIAL CHAPTER 2 (euros)	38.226.502,40 €
CHAPTER 3.- INSTALLATIONS	
2.1 CONSTRUCTION INSTALLATIONS	641.750,00 €
2.2 UNDEGROUND INSTALLATIONS	9.993.420,00 €
2.3 SURFACE INSTALLATIONS	251.650,00 €
PARTIAL CHAPTER 3 (euros)	10.886.820,00 €
CHAPTER 4.- ENVIRONMENTAL MANAGEMENT	
4.1 ENVIRONMENTAL MANAGEMENT	700.000,00 €
PARTIAL CHAPTER 4 (euros)	700.000,00 €
CHAPTERS 1 TO 4 (euros)	160.509.237,50 €
HEALTH AND SAFETY	2.407.639,00 €
UNDERGROUND MONITORING	481.528,00 €
FURTHER SUBSOIL EXPLORATION	1.029.354,00 €
DETAILED DESIGN AND PROFESSIONAL ASSOCIATION FEES	2.639.910,76 €
TOTAL CONSTRUCTION COST	167.067.669,26 €
13% OVERHEAD EXPENSES	21.718.797,00 €
6% INDUSTRIAL PROFIT	10.024.060,16 €
TOTAL CONTRACTOR BUDGET	198.810.526,42 €
16% VAT	31.809.684,23 €
TOTAL TENDER COST	230.620.210,65 €

GLACIER

CHAPTER 1.- MDC EXCAVATION	
1.1 MDC EXCAVATION	14.900.941,42 €
1.2 MDC SUPPORT	9.381.232,69 €
PARTIAL CHAPTER 1 (euros)	24.282.174,11 €
CHAPTER 2.- ACCESS GALLERIES AND CAVERN EXCAVATIONS AND SUPPORT	
2.1 ACCESS GALLERIES	17.128.604,17 €
2.2 AUXILIARY CAVERNS	1.182.241,56 €
2.3 VENTILATION GALLERY AND SHAFT	8.151.843,43 €
PARTIAL CHAPTER 2 (euros)	26.462.689,17 €
CHAPTER 3.- INSTALLATIONS	
2.1 CONSTRUCTION INSTALLATIONS	641.750,00 €
2.2 UNDEGROUND INSTALLATIONS	6.213.500,00 €
2.3 SURFACE INSTALLATIONS	251.650,00 €
PARTIAL CHAPTER 3 (euros)	7.106.900,00 €
CHAPTER 4.- ENVIRONMENTAL MANAGEMENT	
4.1 ENVIRONMENTAL MANAGEMENT	620.000,00 €
PARTIAL CHAPTER 4 (euros)	620.000,00 €
CHAPTERS 1 TO 4 (euros)	68.471.763,28 €
HEALTH AND SAFETY	877.078,00 €
UNDERGROUND MONITORING	239.887,00 €
FURTHER SUBSOIL EXPLORATION	617.812,40 €
DETAILED DESIGN AND PROFESSIONAL ASSOCIATION FEES	1.289.035,27 €
TOTAL CONSTRUCTION COST	81.489.373,85 €
13% OVERHEAD EXPENSES	7.891.018,81 €
6% INDUSTRIAL PROFIT	3.888.162,44 €
TOTAL CONTRACTOR BUDGET	73.148.555,00 €
16% VAT	11.703.788,80 €
TOTAL TENDER COST	84.852.323,80 €

How long will it take ????

MEMPHYS

		MEMPHYS MDC's. CONSTRUCTION TIMETABLE																																																																																			
		MONTHS																																																																																			
PART OF CIVIL WORKS		YEAR 1							YEAR 2							YEAR 3							YEAR 4							YEAR 5							YEAR 6							YEAR 7																																									
		1	2	3	4	5	6	7	8	9	10	11	12	13	14	15	16	17	18	19	20	21	22	23	24	25	26	27	28	29	30	31	32	33	34	35	36	37	38	39	40	41	42	43	44	45	46	47	48	49	50	51	52	53	54	55	56	57	58	59	60	61	62	63	64	65	66	67	68	69	70	71	72	73	74	75	76	77	78	79	80	81	82	83	84
ACCESS GALLERY																																																																																					
	Tunnel portal																																																																																				
	Excavation and support access gallery AG1																																																																																				
	Upper chamber AC1																																																																																				
	Connection gallery upper chamber to upper level MDC																																																																																				
	Individual connections to MDC domes																																																																																				
	Connection with shaft																																																																																				
	Widening of railway tunnel and connection to shaft																																																																																				
	Raise boring																																																																																				
VENTILATION GALLERY																																																																																					
	Excavation and support ventilation gallery AG1																																																																																				
	Raise Boring of ventilation shaft																																																																																				
ACCESS GALLERY TO LOWER LEVEL MDC																																																																																					
	Excavation and support access gallery AG1 to lower level MDC3																																																																																				
	Excavation and support access gallery AG1 to lower level MDC2																																																																																				
	Excavation and support access gallery AG1 to lower level MDC1																																																																																				
AUXILIARY CAVERN CONSTRUCTION																																																																																					
	Excavation and support AC2's (Water purification)																																																																																				
	Excavation and support AC1+AC3 (Control, storage & power transf)																																																																																				
CONSTRUCTION MDC-3																																																																																					
	Excavation and support lower perimetral gallery																																																																																				
	Ribs to level 1210,48																																																																																				
	Excavation and support lower perimetral gallery																																																																																				
	Ribs to upper cavern																																																																																				
	Excavation and support of upper dome																																																																																				
	Concrete pouring for ribs and galleries																																																																																				
	Excavation y support dome																																																																																				
	Raise boring (MDC)																																																																																				
	Excavation and support (cylinder) (m3)																																																																																				
CONSTRUCTION MDC-2																																																																																					
	Excavation and support lower perimetral gallery																																																																																				
	Ribs to level 1210,48																																																																																				
	Excavation and support lower perimetral gallery																																																																																				
	Ribs to upper cavern																																																																																				
	Excavation and support of upper dome																																																																																				
	Concrete pouring for ribs and galleries																																																																																				
	Excavation y support dome																																																																																				
	Raise boring (MDC)																																																																																				
	Excavation and support (cylinder) (m3)																																																																																				
CONSTRUCTION MDC-1																																																																																					
	Excavation and support lower perimetral gallery																																																																																				
	Ribs to level 1210,48																																																																																				
	Excavation and support lower perimetral gallery																																																																																				
	Ribs to upper cavern																																																																																				
	Excavation and support of upper dome																																																																																				
	Concrete pouring for ribs and galleries																																																																																				
	Excavation y support dome																																																																																				
	Raise boring (MDC)																																																																																				
	Excavation and support (cylinder) (m3)																																																																																				

Summary / Conclusions

- A very detailed feasibility study for LAGUNA at the LSC has been performed with positive results

It is documented in the almost final (but yet **preliminary**) LAGUNA-WP2's "Interim Report for the LSC" (<http://www.lsc-canfranc.es/> → activity → LAGUNA) *I brought a paper copy should you want to have a look today*

- Many items have not been presented here due to lack of time (in particular installations and auxiliary infrastructures). Please have a look to the above documents
- The Canfranc area is excellent to provide the social / living needs of the people forming a large Collaboration like LAGUNA

The LSC is found to be very well suited to locate any of the LAGUNA experiments

- However much work is yet to be done to solve the equation
technology + location + beam = excellent_physics
- The UAM and LSC are working hard on it